



DATASHEET

AUTOMATIC SCREW FEEDER NSRI

v1.1

1. Datasheet

1.1. Screw Feeder NSRI

General property	Description/Value	Unit
Power AC adapter (switching type)	Input: AC 100~240 50/60	[V] [Hz]
	Output: DC 15 1	[V] [A]
Dimensions (W, D, H)	123 x 181 x 145	[mm]
	4.8 x 7.1 x 5.7	[inch]
Weight (including rail)	Approximately 3	[kg]
	Approximately 6.6	[lb]
Screw capacity	Approximately 300 cc	
Following accessories	Operation Manual 1 copy AC Adapter 1 unit Hexagonal wrench 1 piece Screwdriver 1 piece Ground wire 1 piece	
Installation location	Level stable place	
Operating and storage temperature	0 - 40	[°C]
Operating and storage humidity (without condensation)	10 - 85	[%]
Compliance standards	ECC: 2014/30/UE	
	RoHS: 2011/65/EU	

Reference table of the specified screws					Shape of screw head						
Screw size	Screw shaft diameter [Ø]	Screw head diameter [Ø]	Screw head thickness [mm]	Screw shaft length [mm]	Pan head			Bind	Flat head	Counter sunk head	Hexagon flange bolt
					Sems	Double sems	Washer head				
M1.0	0.9 ~ 0.95	1.2 ~ 4.5	0.35 ~ 1.0	1.6 ~ 10					x		
M1.2	1.1 ~ 1.15	1.4 ~ 4.5	0.35 ~ 1.0	1.8 ~ 10					x		
M1.4	1.3 ~ 1.4	1.7 ~ 4.5	0.35 ~ 1.0	2.0 ~ 10					x		
M1.7	1.6 ~ 1.7	2.0 ~ 4.5	0.35 ~ 1.0	2.3 ~ 10					x		
M2.0	1.9 ~ 2.1	2.4 ~ 6	0.35 ~ 4.5	2.6 ~ 20	x	x	x	x	x	x	x

Reference table of the specified screws					Shape of screw head						
Screw size	Screw shaft diameter [Ø]	Screw head diameter [Ø]	Screw head thickness [mm]	Screw shaft length [mm]	Pan head			Bind	Flat head	Counter sunk head	Hexagon flange bolt
					Sems	Double sems	Washer head				
M2.3	2.2 ~ 2.4	2.7 ~ 6	0.35 ~ 4.5	2.9 ~ 20	x	x	x	x	x	x	x
M2.6	2.5 ~ 2.7	3.0 ~ 6	0.35 ~ 4.5	3.2 ~ 20	x	x	x	x	x	x	x
M3.0	2.9 ~ 3.2	3.5 ~ 6	0.35 ~ 4.5	3.6 ~ 20	x	x	x	x	x	x	x

**NOTE:**

Please consult your distributor for thin head.

Check if the axis diameter of the loaded screw corresponds with the below rail groove width.

With the range of screw size and lengths below, there may be instances of unique screw shape or structure not compatible with the screw feeder unit.

In the main body type, the main body model can be changed.

To change the nominal diameter of loaded screw, replace it with a part that is mentioned in the next page table.

The rail, escaper, robot escaper guide and passing plate are separately available for replacement.

The design, performance and specifications are subject to change without prior notice for the sake of improvement.

The noise of this unit is less than LAeq 70 dB at a distance of 1 m.

This product complies with EC directive. Please check the EC Declaration of Conformity for compliance standards.

Screw feeder series	Screw feeder model	Screw size	Exchange kit No.	Rail model No.	Escaper model No.	Robot escaper guide model No.	Passing plate model No.
NSRI	NSRI10	M1.0	RI10SET (T213)	RI10	TOKX0239 #01	TOKX0240 #01	SW1017
	NSRI12	M1.2	RI12SET (T213)	RI12	TOKX0239 #02		
	NSRI14	M1.4	RI14SET (T213)	RI14	TOKX0239 #03		
	NSRI17	M1.7	RI17SET (T213)	RI17	TOKX0239 #04		
	NSRI20	M2.0	RI20SET (T213)	RI20	TOKX0239 #05	TOKX0240 #02	SW2030
	NSRI23	M2.3	RI23SET (T213)	RI23	TOKX0239 #06		
	NSRI26	M2.6	RI26SET (T213)	RI26	TOKX0239 #07		
	NSRI30	M3.0	RI30SET (T213)	RI30	TOKX0239 #08		

**NOTE:**

In the Exchange kit ordered, Rail assembly, Escaper, Robot escaper guide and Passing plate are included.

Please contact us by “~ SET” type when you need rail.

1.2. Screw Feeder NSRI box content

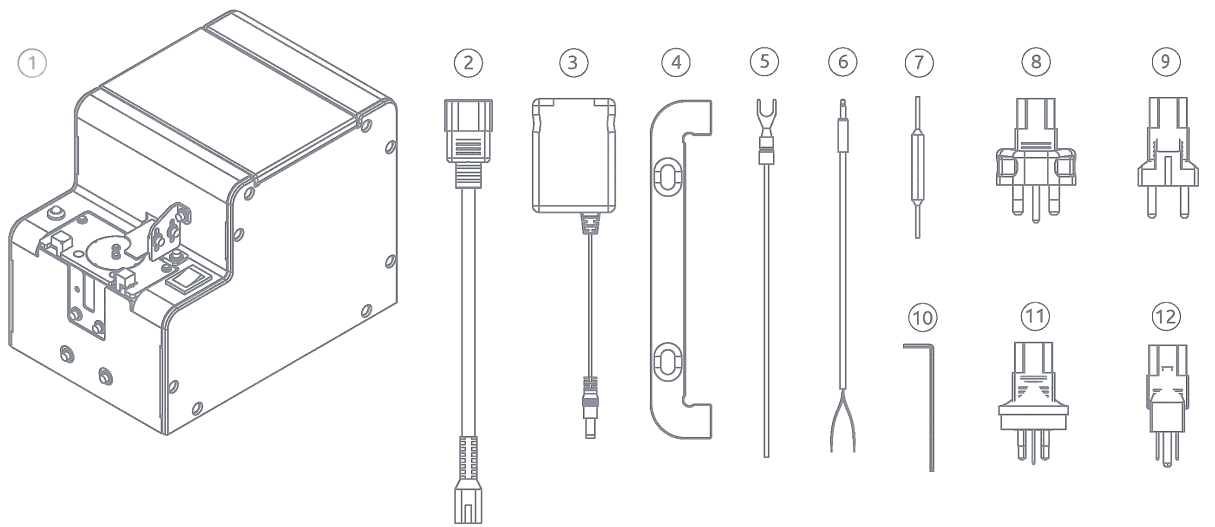

- | | | | |
|--------------------------|---|-----------------------|--------------------------|
| ① Screw Feeder NSRI M1.6 | ② 2 poles Male C14 - C7 2 pol 1,8 meter | ③ AC adapter 15V NSRI | ④ 2 x NSRI (M1.6) Fixing |
| ⑤ Grounding cable | ⑥ Mini Jack to I/O - 1.8m | ⑦ Screwdriver | ⑧ UK Plug to C13 |
| ⑨ EU Plug to C13 | ⑩ Metric Hex Key 2 mm | ⑪ AS Plug to C13 | ⑫ US Plug to C13 |

1.3. Screw Feeder NSRI

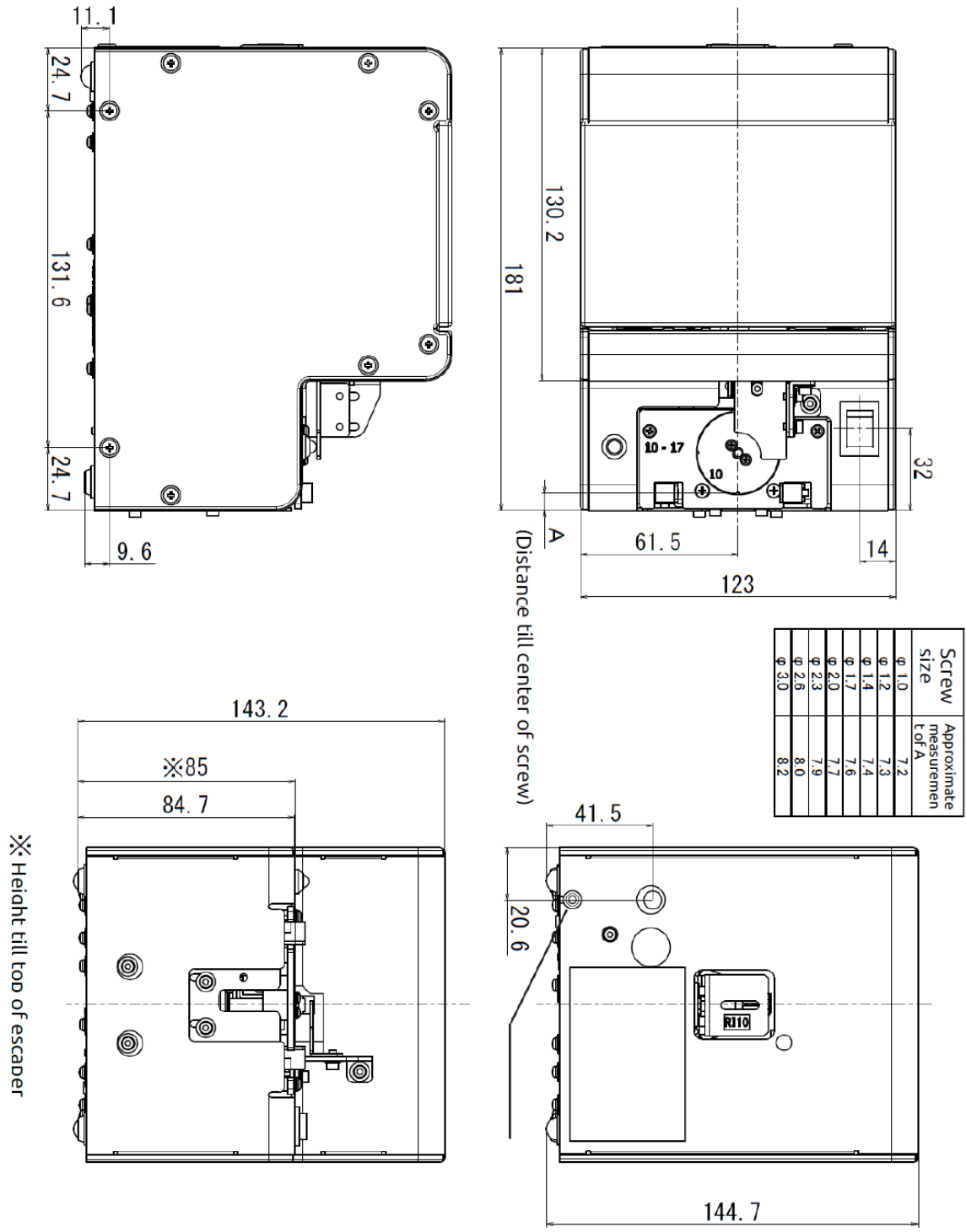

All dimensions are in mm.

1.4. Screw Feeder NSRI - Mounting Fixture

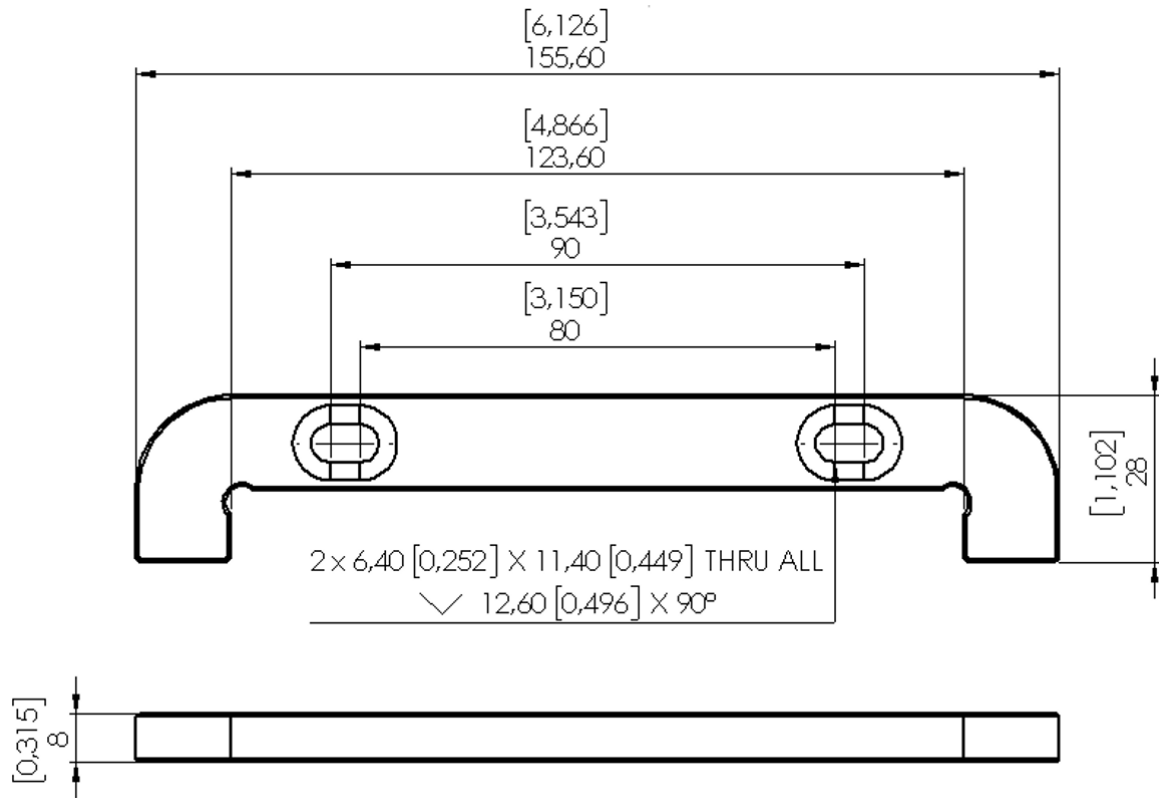

All dimensions are in mm and [inches].



DATASHEET

AUTOMATIC SCREW FEEDER OM-26R

v1.1

1. Datasheet

1.1. Screw Feeder OM-26R

General property	Description/Value	Unit
Power AC adapter (switching type)	Input: AC 100~240 50/60	[V] [Hz]
	Output: DC 15 1	[V] [A]
Dimensions (W, D, H)	119 x 226 x 152	[mm]
	46.8 x 88.9 x 59.8	[inch]
Weight (including rail)	Approximately 3.1	[kg]
	Approximately 6.8	[lb]
Screw capacity	Approximately 300 cc	
Following accessories	Operation Manual 1 copy AC Adapter 1 unit Hexagonal wrench 1 piece Screwdriver 1 piece Ground wire 1 piece	
Installation location	Level stable place	
Operating and storage temperature	0 - 40	[°C]
Operating and storage humidity (without condensation)	10 - 85	[%]
Compliance standards	ECC: 2014/30/UE	
	RoHS: 2011/65/EU	

Reference table of the specified screws						Shape of screw head					
Screw size	Screw shaft diameter [Ø]	Screw head diameter [Ø]	Washer diameter [Ø]	Screw head thickness [mm]	Screw shaft length [mm]	Pan head			Bind	Flat head	Hexagon flange bolt
						Sems	Double sems	Washer head			
Ø 2.0	1.9 ~ 2.1	2.4 ~ 6	2.4 ~ 10	0.35 ~ 6	2.6 ~ 25	x	x	x	x	x	x
Ø 2.3	2.2 ~ 2.4	2.7 ~ 6	2.7 ~ 10	0.35 ~ 6	2.9 ~ 25	x	x	x	x	x	x
Ø 2.6	2.5 ~ 2.7	3.0 ~ 6	3.0 ~ 10	0.35 ~ 6	3.2 ~ 25	x	x	x	x	x	x
Ø 3.0	2.9 ~ 3.2	3.5 ~ 6	3.5 ~ 11	0.35 ~ 6	3.6 ~ 25	x	x	x	x	x	x
Ø 3.5	3.4 ~ 3.7	4.0 ~ 8	4.0 ~ 11	0.35 ~ 6.5	4.1 ~ 25	x	x	x	x	x	x

Reference table of the specified screws						Shape of screw head					
Screw size	Screw shaft diameter [Ø]	Screw head diameter [Ø]	Washer diameter [Ø]	Screw head thickness [mm]	Screw shaft length [mm]	Pan head			Bind	Flat head	Hexagon flange bolt
						Sems	Double sems	Washer head			
Ø 4.0	3.8 ~ 4.2	4.5 ~ 8	4.5 ~ 12	0.35 ~ 6.5	4.6 ~ 25	x	x	x	x	x	x
Ø 5.0	4.8 ~ 5.2	5.5 ~ 10	5.5 ~ 12	0.35 ~ 7	5.6 ~ 25	x	x	x	x	x	x
Ø 6.0	5.8 ~ 6.2	6.5 ~ 11	6.5 ~ 12	0.35 ~ 7.5	6.6 ~ 25	x	x	x	x	x	x

**NOTE:**

Compatible with washer thickness 0.35 to 1.6 mm.

**CAUTION:**

This machine accepts only steel screws. Plastic or stainless screws cannot be used.

Check if the axis diameter of the loaded screw matches the rail groove width.

Within the range of screw size and length below, there may be instances of unique screw shape or structure not compatible with the feeder unit.

To use a screw with a different diameter, match it with the corresponding parts mentioned in the table above.

The rail, escaper, escaper guide, and passing plate are available, separately, for replacement.

The design, performance and specifications are subject to change, for the sake of improvement, without prior notice.

The noise of this unit is less than LAeq 70 dB at a distance of 1 m.

This product complies with EC directive. Please check the EC Declaration of Conformity for compliance standards.

Screw feeder series	Screw feeder model	Screw size	Exchange kit No.	Rail model No.	Escaper model No.	Robot escaper guide model No.	Passing plate model No.
OM-26R	OM-26R20	Ø 2.0	OMR20SET (T212)	OMR20	TOKX0239 #05	TOKX0240 #02	OM20-30
	OM-26R23	Ø 2.3	OMR23SET (T212)	OMR23	TOKX0239 #06		
	OM-26R26	Ø 2.6	OMR26SET (T212)	OMR26	TOKX0239 #07		
	OM-26R30	Ø 3.0	OMR30SET (T212)	OMR30	TOKX0239 #08		
	OM-26R35	Ø 3.5	OMR35SET (T212)	OMR35	TOKX0239 #09	TOKX0240 #03	OM35-40
	OM-26R40	Ø 4.0	OMR40SET (T212)	OMR40	TOKX0239 #10		
	OM-26R50	Ø 5.0	OMR50SET (T212)	OMR50	TOKX0239 #11	TOKX0240 #04	OM50
	OM-26R60	Ø 6.0	OMR60SET (T212)	OMR60	TOKX0239 #12		OM60

**NOTE:**

In the Exchange kit ordered, Rail assembly, Escaper, Robot escaper guide and Passing plate are included.

Please contact us by “~ SET” type when you need rail.

1.2. Screw Feeder OM-26R box content

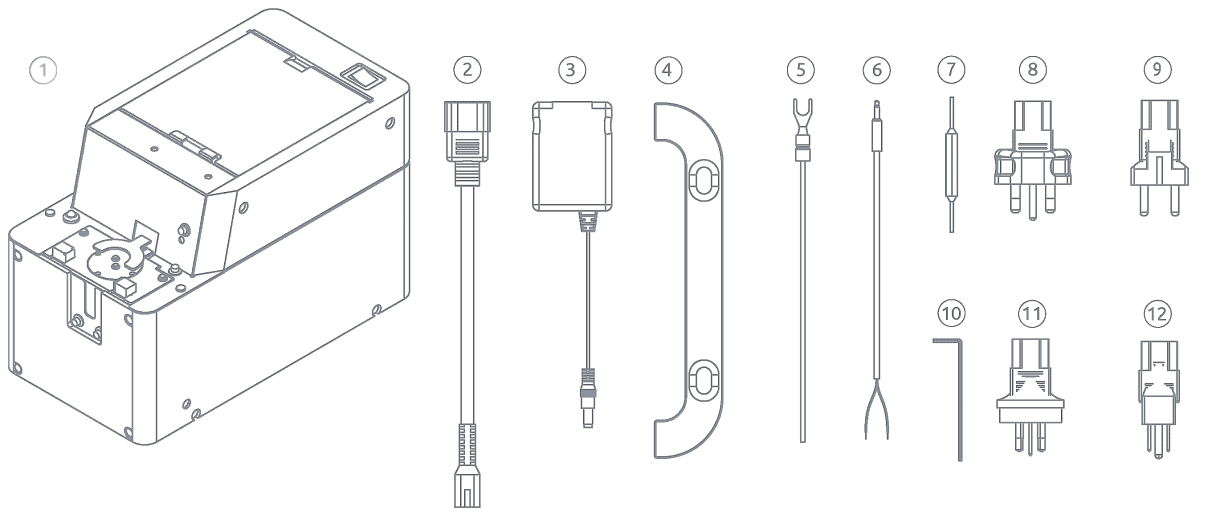

- | | | | |
|--|--|-----------------------|--------------------------|
| ① Screw Feeder M2-M6
(Thread size: See outside box) | ② 2 poles Male C14 - C7
2 pol 1,8 meter | ③ AC adapter 15V NSRI | ④ OM-26R30 (M2-M6) Mount |
| ⑤ Grounding cable | ⑥ Mini Jack to I/O - 1.8m | ⑦ Screwdriver | ⑧ UK Plug to C13 |
| ⑨ EU Plug to C13 | ⑩ Metric Hex Key 2 mm | ⑪ AS Plug to C13 | ⑫ US Plug to C13 |

1.3. Screw Feeder OM-26R

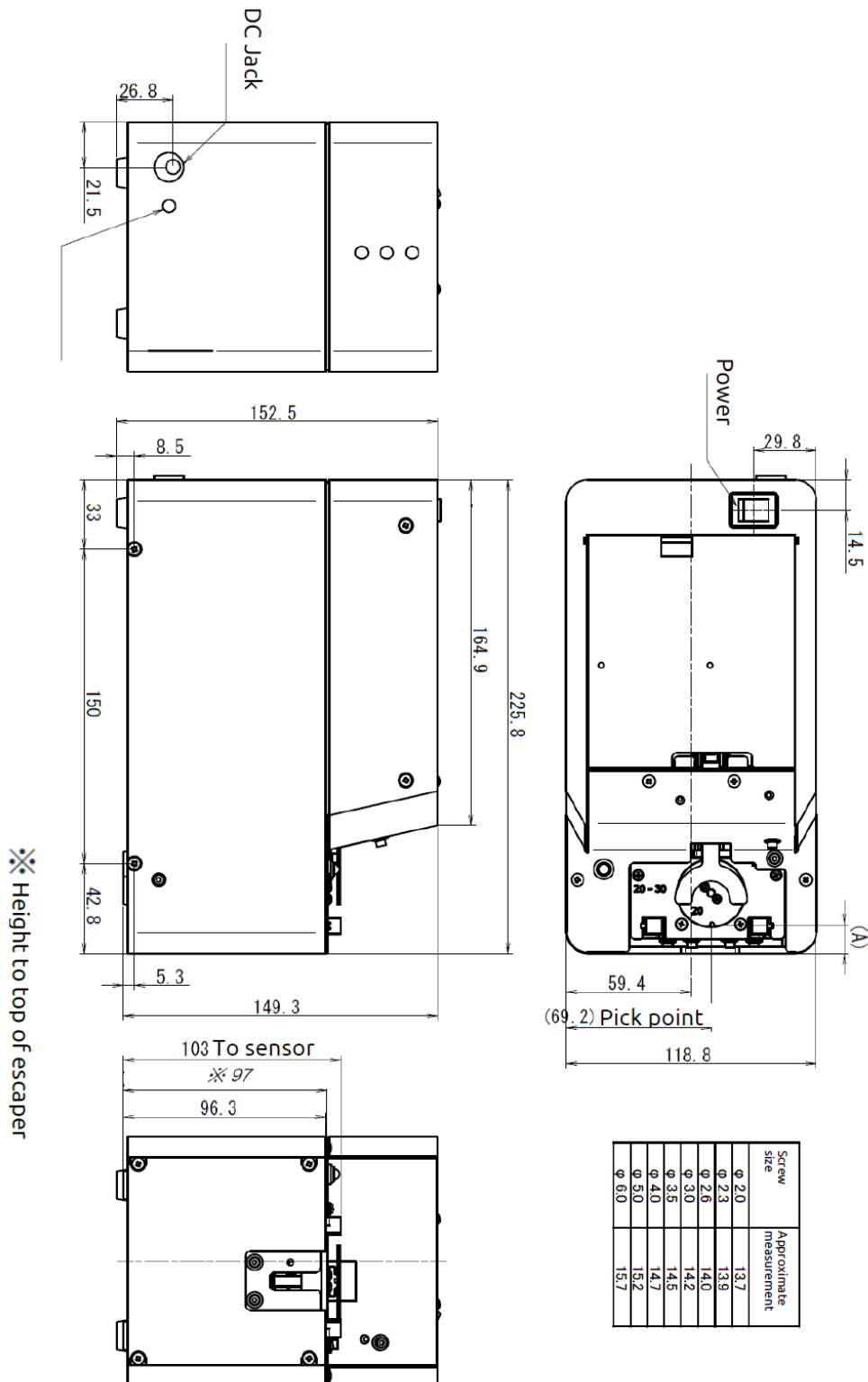

All dimensions are in mm.

1.4. Screw Feeder OM-26R - Mounting Fixture

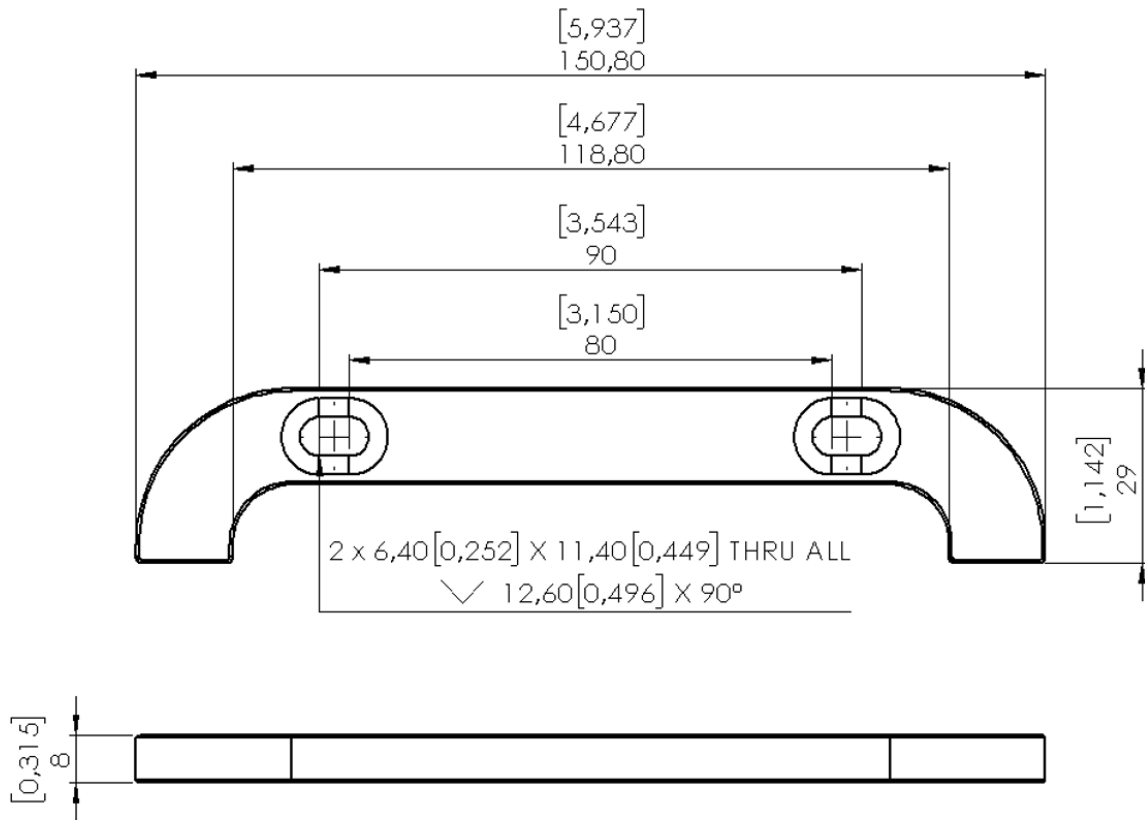

All dimensions are in mm and [inches].