





# DATASHEET

3FG15

v1.3

# 1. Datasheet

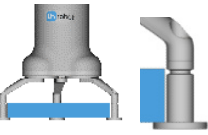
## 1.1. 3FG15

General Properties		Minimum	Typical	Maximum	Unit
Payload Force Fit		-	-	10	[kg]
		-	-	22	[lb]
Payload Form Fit		-	-	15	[kg]
		-	-	33	[lb]
Grip Diameter*	External 	4 0.16	- -	152 5.98	[mm] [inch]
	Internal 	35 1.38	- -	176 6.93	[mm] [inch]
Finger position resolution		- -	0.1 0.004	- -	[mm] [inch]
Diameter repetition accuracy		- -	0.1 0.004	0.2 0.007	[mm] [inch]
Gripping force		10	-	240	[N]
Gripping force (adjustable)		1	-	100	[%]
Gripping speed (diameter change)		-	-	125	[mm/s]
Gripping time (including brake activation)**		-	500	-	[ms]
Hold workpiece if power loss?		Yes			
Storage temperature		0 32	- -	60 122	[°C] [°F]
Motor		Integrated, electric BLDC			
IP Classification		IP67			
Dimensions [L, W, Ø]		156 x 158 x 180 6.14 x 6.22 x 7.08			[mm] [inch]
Weight		1.15 2.5			[kg] [lb]

\* With the scope of delivery

\*\* 10 mm diameter distance. Also see section [Finger Movement and Force](#)

Operating Conditions	Minimum	Typical	Maximum	Unit
Power supply	20	24	25	[V]

Operating Conditions	Minimum	Typical	Maximum	Unit
Current consumption	43	-	1500*	[mA]
Operating temperature	5	-	50	[°C]
	41	-	122	[°F]
Relative humidity (non-condensing)	0	-	95	[%]
Calculated operation life	30 000	-	-	[Hours]

\*600 mA set as default.

### Fingers

The supplied fingers can be mounted in 3 different positions to achieve different **Gripping Forces** and different **Gripping Diameters**.

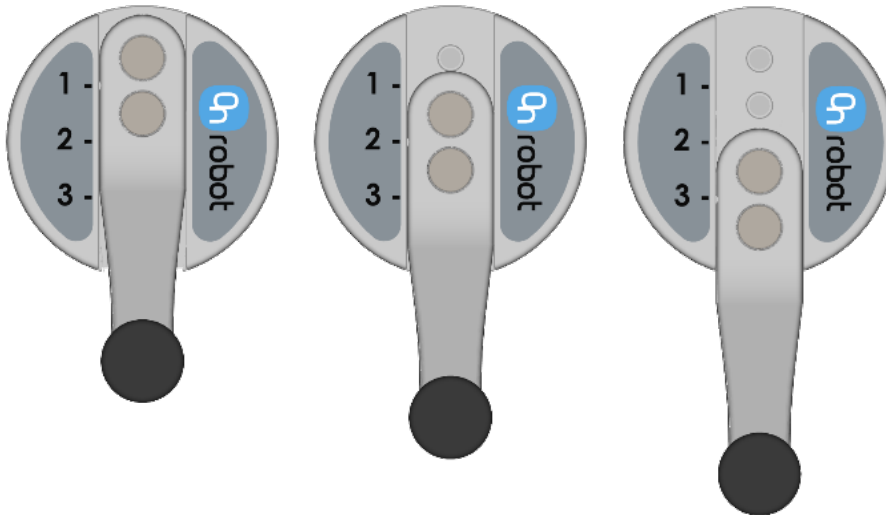

The delivered finger length is 49 mm (L in the drawing below). If custom fingers are required, they can be made to fit the Gripper according to the dimensions (mm)[inch] shown below. The needed screws are M4x8mm (use 3 Nm tightening torque):

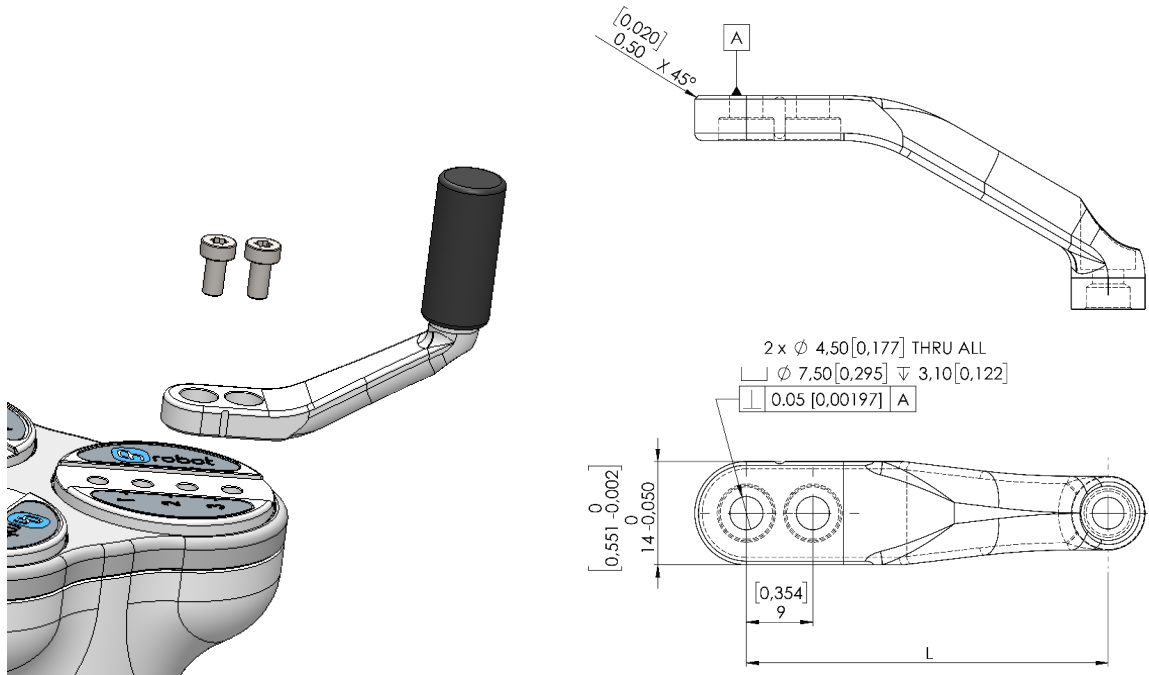

### Fingertips

The supplied fingertips are listed below. Different fingertips will allow to achieve different **Gripping Forces** and different **Gripping Diameters**.

- Ø10 mm steel
- Ø13 mm steel
- Ø13.5 mm silicone
- Ø16.5 mm silicone

If custom fingertips are required, they can be made to fit the Gripper's fingers according to the dimensions (mm)[inch] shown below. The needed screws are M4x8mm:

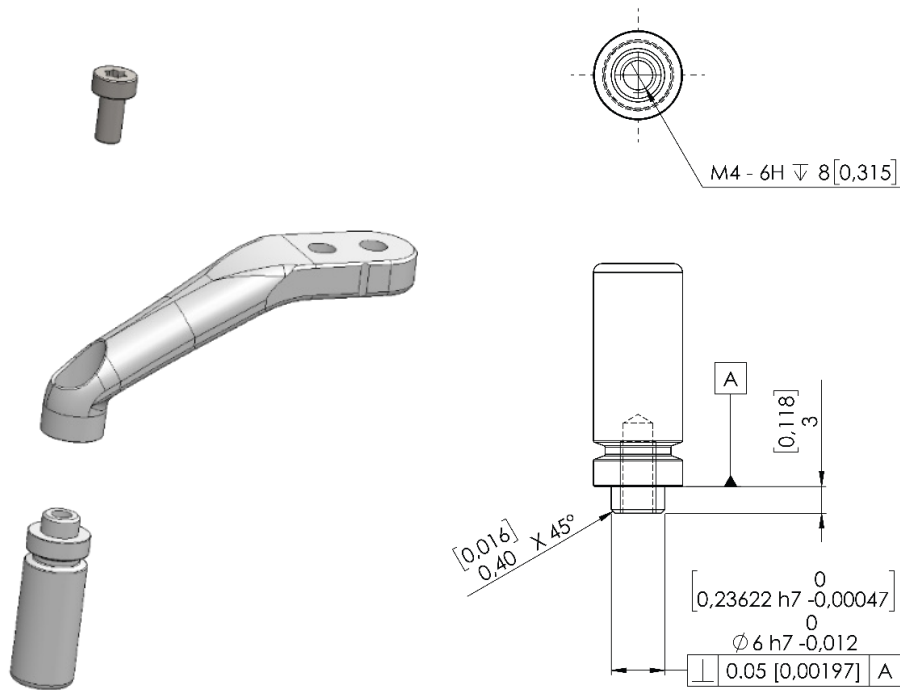

In the graph below, the maximum payload allowed for customized fingertip given a length is shown.

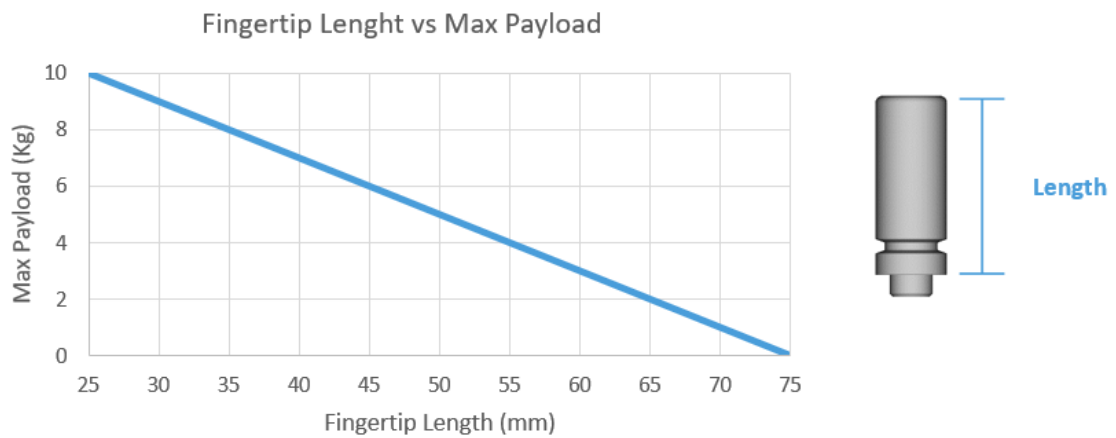

In the graph below, how the % of maximum achievable force decreases as the finger length increases when customized fingertips are used.

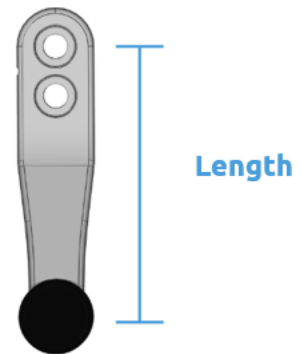
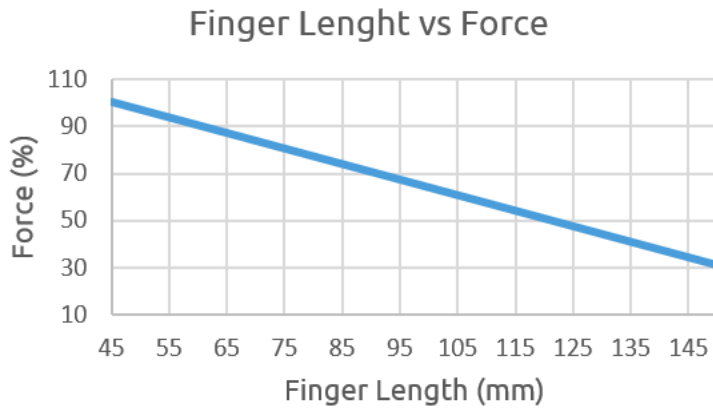

### X-shape fingertips

These fingertips improve the gripper's ability to pick and place round workpieces with collar like features. By combining the force fit and the form fit gripping approaches, the fingertips increase the stability and payload of the workpiece to be gripped.

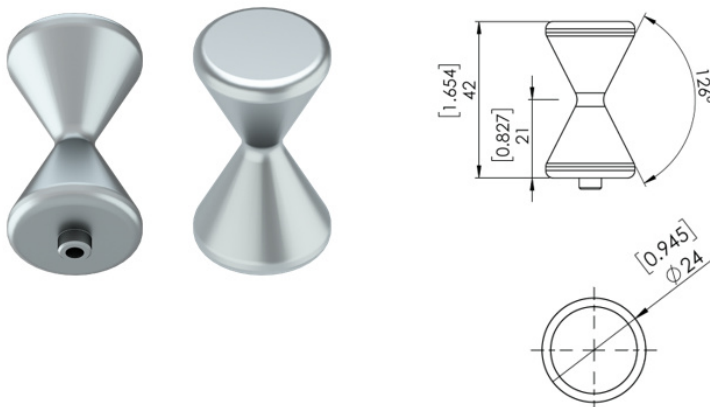

When these fingertips are used, set the fingertip diameter to 16 mm in the robot program. These fingertips are optional accessories and need to be purchased separately. To purchase these fingertips, please contact the distributor.

- 3FG X-Shape fingertips PN 105877

### Types of Grips

In the document the internal and external grip terms are used. These grips are related to how the workpiece is gripped.

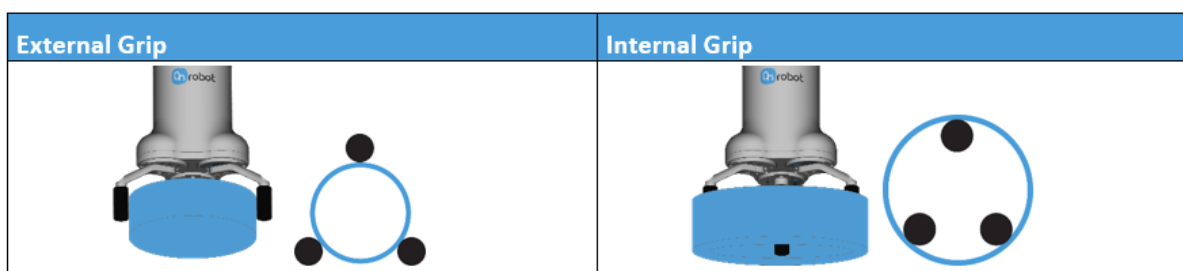

### Gripping Force

The total gripping force highly depends on the finger angle  $\theta$ . For both internal and external grip, the lower the finger angle, the higher the force that will be applied as shown in the graph below.

Although the fingers can move from 0 to 180, the angle range of an external grip is 30°-165° and for an internal grip 20°-160°

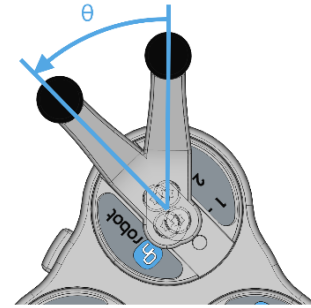

### Maximum Force and Finger Angle $\theta$

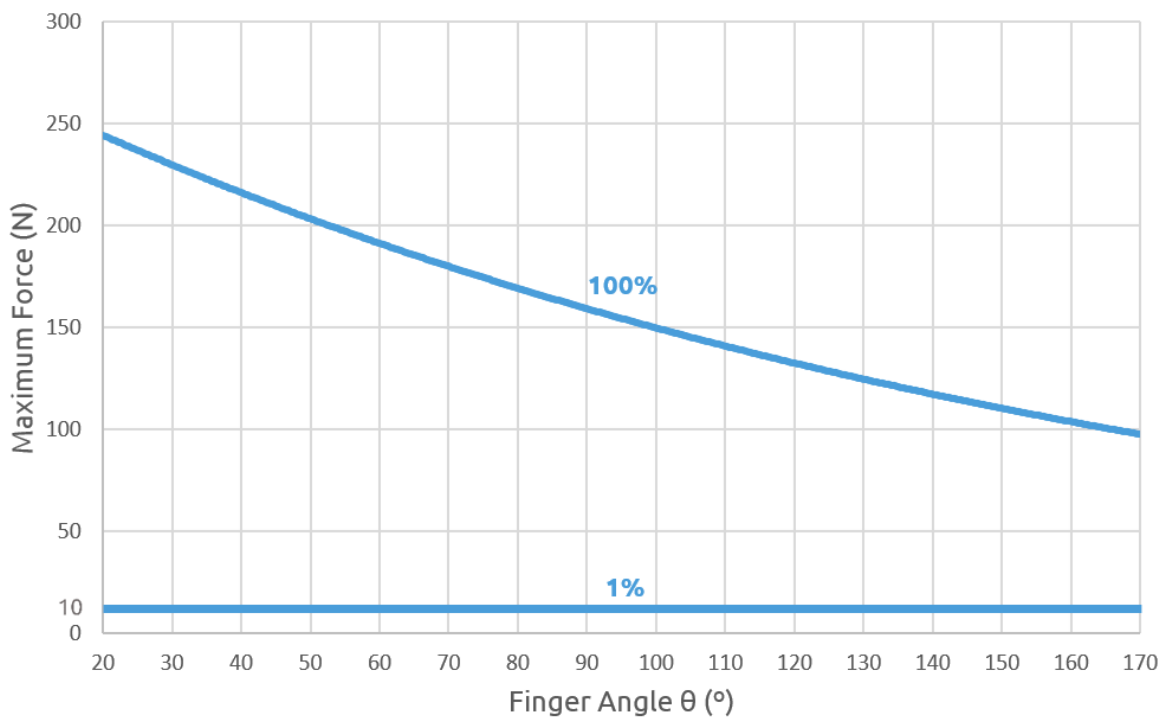

Graph plotted using measurements with 1 A current, silicone fingertips and a metal workpiece.



**NOTE:**

The total force applied depends on the finger angle, the input current (limited in some robots' tool flange connection) and the friction coefficient between the materials of the fingertips and the workpiece.

### Finger Movement and Force

The gripping action has two phases:

Phase 1: For a safety reason, the fingers will start moving with a low force (maximum ~50 N) to avoid damaging anything that could get clamped between the gripper fingers and the workpiece.

Phase 2: When the gripper diameter is very close to the programmed target diameter, the gripper will increase the force to grip with the programmed target force. After the grip, a brake will be activated (tic sound). The activation of the brake, also known as, Force grip detected, can be verified in the GUI. This brake will hold the workpiece with the applied force, with no power consumption and holding the workpiece in case of power loss. This brake will automatically be deactivated when the gripper performs a release or a new grip command. While programming the gripper, the brake can be deactivated by using the features in the GUI.

### Gripping Diameter

The different configurations of the delivered finger and fingertips allow to achieve a wide range of diameters.

Finger Position	Fingertip (mm)	External Gripping range (mm)	Internal Gripping range (mm)
1	Ø10	10 - 117	35 - 135
	Ø13	7 - 114	38 - 138
	Ø16.5	4 - 111	41 - 140
2	Ø10	26 - 134	49 - 153
	Ø13	23 - 131	52 - 156
	Ø16.5	20 - 128	55 - 158
3	Ø10	44 - 152	65 - 172
	Ø13	41 - 149	68 - 174
	Ø16.5	38 - 146	71 - 176

Based on:

- Angle for external gripping min 165° (Pos 1), 163 ° (Pos 2), 161 ° (Pos 3) and max 30° (all 3 positions)
- Angle for internal gripping min 160° and max 30°

The closer to the maximum diameter range, the lower the angle and, therefore, the higher the force.



## 1.2. 3FG15

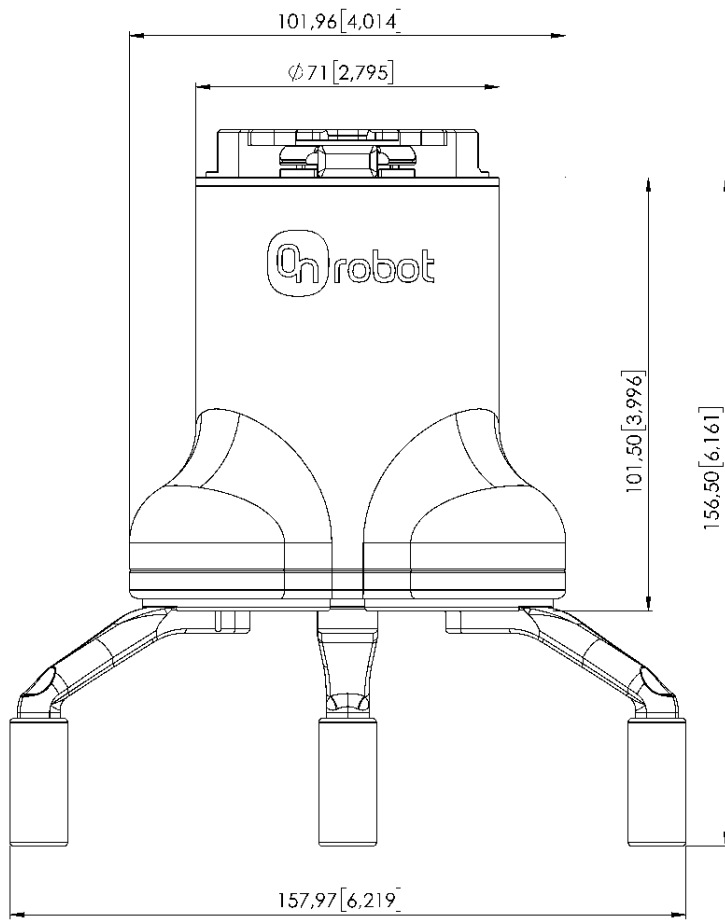

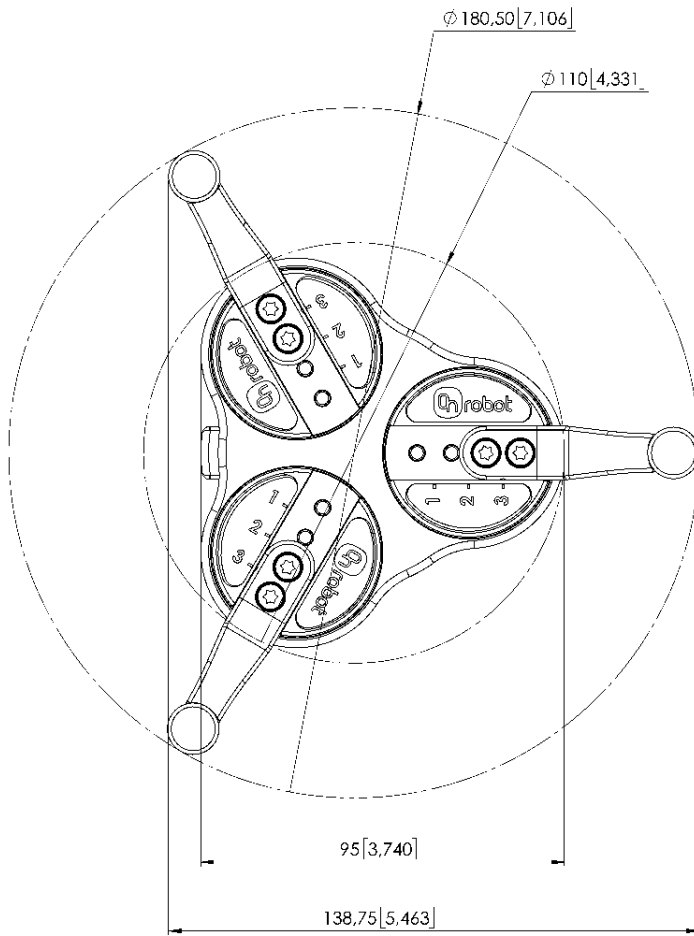

All dimensions are in mm and [inches].